

$$2) -\frac{Gm}{d}[(4 + \sqrt{2})M + 4\sqrt{2}m]$$

$$3) -\frac{Gm}{d}[3m^2 + 4\sqrt{2}M]$$

$$4) -\frac{Gm}{d}[6m^2 + 4\sqrt{2}M]$$

- 16) Displacement current goes through the gap between the plates of a capacitor when the charge on the capacitor [New NCERT /XII/203]

1) is changing with time

2) decreases

3) does not change

4) decreases zero

- 17) A ray of light passes from vacuum into a medium of refractive index μ the angle of incident is found to be twice the angle of refraction. Then the angle of incidence is [New NCERT /XII/228]

$$1) 2\cos^{-1}\left(\frac{\mu}{2}\right)$$

$$2) \sin^{-1}(\mu)$$

$$3) \sin^{-1}\left(\frac{\mu}{2}\right)$$

$$4) \cos^{-1}\left(\frac{\mu}{2}\right)$$

- 18) In a Young's double-slit experiment, let β be the width, and let I_0 be the intensity at the central bright fringe. At a distance x from the central bright fringe, the intensity will be [New NCERT /XII/264,266]

$$1) I_0 \cos\left(\frac{x}{\beta}\right)$$

$$2) I_0 \cos^2\left(\frac{x}{\beta}\right)$$

$$3) I_0 \cos^2\left(\frac{\pi x}{\beta}\right)$$

$$4) \left(\frac{I_0}{4}\right) \cos^2\left(\frac{\pi x}{\beta}\right)$$

- 19) A hydraulic automobile lift is designed to lift vehicles of mass 500 kg. The area of cross-section of the cylinder smaller piston would have to bear is [Assume $g=10\text{m/s}^2$] [New NCERT /XI/185]

$$1) 200 \times 10^6 \text{ Pa}$$

$$2) 20 \times 10^6 \text{ Pa}$$

$$3) 2 \times 10^6 \text{ Pa}$$

$$4) 2 \times 10^5 \text{ Pa}$$

- 20) Given below are two statements: In the light of the given Statements .choose the correct answer from the options given. [New NCERT /XII/283]

Statement I: The photon behaves like a particle

Statement II: If E and P are the energy and momentum of the photon, then $p=E/c$

1) Both statement I and II are correct

2) Both statement I and II are incorrect

3) Both statement I correct but statement II is in correct

4) Statement II is correct but statement I is in correct

- 21) M_p denotes the mass of a proton and M_n that of a neutron A given nucleus, of binding energy B , contains Z protons and N neutrons . The mass $M(N,Z)$ of the nucleus is given by (c is the velocity of light) [New NCERT /XII/311]

$$1) M(N,Z)=NM_n+ZM_p+B/c^2$$

$$2) M(N,Z)=NM_n+ZM_p-Bc^2$$

$$3) M(N,Z)=NM_n+ZM_p+Bc^2$$

$$4) M(N,Z)=NM_n+ZM_p-B/c^2$$

- 22) The physical quantity that has no dimension is [New NCERT /XI/155 Appendix]

1) strain

2) angular velocity

3) angular momentum

4) linear momentum

- 23) Choose the correct equation to determine distance in a straight line for a body with uniform motion. [New NCERT /XI/16]

$$1) s = \frac{v}{t}$$

$$2) s = v^2 t$$

3) $s = ut + \frac{1}{2}at^2$

4) $s = vx t^2$

- 24) A spring whose unstretched length is l has a force constant k . The spring is cut into two pieces of unstretched lengths l_1 and l_2 where $l_1 = nl_2$ and n is an integer. The ratio k_1/k_2 of the corresponding force constants, k_1 and k_2 will be: **[New NCERT /XI/80]**

- 1) n 2) $\frac{1}{n^2}$ 3) $\frac{1}{n}$ 4) n^2

- 25) The electric potential at a point (x, y) in the x - y plane is given by $V = -kxy$. The field intensity at a distance r from the origin varies as **[New NCERT /XII/55]**

- 1) r^2 2) r 3) $\frac{1}{r}$ 4) $\frac{1}{r^2}$

- 26) An iron bar of length l cm and cross section A cm² is pulled by a force of F dynes from ends so as to produce an elongation Δl cm. Which of the following statement is correct? **[New NCERT /XI/170]**

- 1) Elongation is inversely proportional to length
 2) Elongation is directly proportional to cross section A
 3) Elongation is inversely proportional to cross section
 4) Elongation is directly proportional to Young's modulus

- 27) Which of the following gates will have an output of 1? **[Old NCERT /XII/493]**

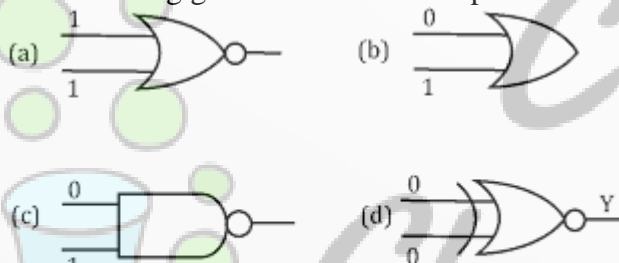

- 1) D 2) A 3) B 4) C

- 28) A student obtained a sharp image of the grill of a window on a screen, using a convex lens. For getting better results, the teacher suggested focusing of a distant tree instead of the grill. In which direction should the lens be removed for this purpose? **[XII/ Practical Skills]**

- 1) Always from the screen
 2) Very far away from the screen
 3) Behind the screen
 4) Towards the screen

- 29) The work function of a substance is 4.0 eV. The longest wavelength of light that can cause photoelectron emission from this substance is approximately **[New NCERT /XII/281]**

- 1) 310nm 2) 400nm 3) 540nm 4) 220nm

- 30) Consider a cylindrical tank of radius 1 m is filled with water. The top surface of water is at 15 m from the bottom of the cylinder. There is a hole on the wall of cylinder at a height of 5 m from the bottom. A force of 5×10^5 N is applied on the top surface of water using a piston. The speed of efflux from the hole will be : (given atmospheric pressure $P_A = 1.01 \times 10^5$ Pa, density of water $\rho_w = 1000$ kg/m³ and gravitational acceleration $g = 10$ m/s²) **[New NCERT /XI/189]**

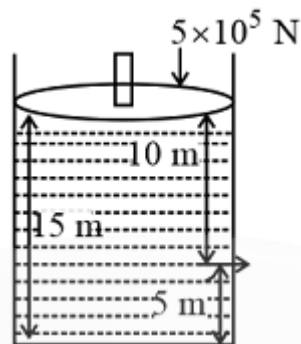

- 1) 11.6 m/s
2) 10.8 m/s
3) 17.8 m/s
4) 14.4 m/s
31. An electric dipole is placed at an angle of 30° to a non-uniform electric field. The dipole will experience [New NCERT /XII/27]
- 1) a translational force only in the direction of the field
 - 2) a translational force only in the direction normal to the direction of the field
 - 3) a torque as well as translational force
 - 4) a torque only
- 32) The linear momentum of a system of particles is equal to [New NCERT /XI/100]
- 1) product of total mass x acceleration
 - 2) product of total mass x velocity
 - 3) product of total mass x velocity of centre of mass
 - 4) product of total mass x acceleration of centre of mass
- 33) A 2 kg copper block is heated to 500°C and then it is placed on a large block of ice at 0°C . If the specific heat capacity of copper is $400\text{J/kg}^\circ\text{C}$ and latent heat of fusion of water is $3.5 \times 10^5\text{ J/kg}$, the amount of ice that can melt is [New NCERT /XI/213]
- 1) (7/8) kg
 - 2) (7/5) kg
 - 3) (8/7) kg
 - 4) (5/7) kg
- 34) Match Column I with Column II. [New NCERT /XI/246,247]
- | | |
|---------------------|------------------------|
| Column I | Column II |
| (A) $P \propto 1/V$ | (1) Ideal gas equation |
| (B) $V \propto T$ | (2) Boyle's law |
| (C) $PV = nRT$ | (3) Charles's law |
| (D) $P \propto T$ | (4) V-constant |
- 1) (A) \rightarrow (4); (B) \rightarrow (2); (C) \rightarrow (3); (D) \rightarrow (1)
 - 2) (A) \rightarrow (1); (B) \rightarrow (2); (C) \rightarrow (3); (D) \rightarrow (4)
 - 3) (A) \rightarrow (2); (B) \rightarrow (3); (C) \rightarrow (1); (D) \rightarrow (4)
 - 4) (A) \rightarrow (3); (B) \rightarrow (4); (C) \rightarrow (2); (D) \rightarrow (2)
- 35) A series combination of n_1 capacitors each capacity C_1 is charged source of potential difference $4V$. When another parallel combination of n_2 capacitor each of capacity C_2 is charged by a source of potential difference V , it has same total energy stored in it as the first combination has. The value of C_2 in terms of C_1 is then [New NCERT /XII/72]
- 1) $16 \frac{n_2}{n_1}$
 - 2) $\frac{2C_1}{n_1 n_2}$
 - 3) $2 \frac{n_2}{n_1} C_1$
 - 4) $\frac{16C_1}{n_1 n_2}$

- 36) The figure below shows currents in a part of electric circuit. The current i is [New NCERT /XII/97,98]

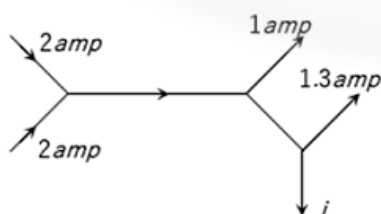

- 1) 1.7 amp
 - 2) 3.7 amp
 - 3) 1.3 amp
 - 4) 1 amp
- 37) The resistance of an ammeter is $13\ \Omega$ and its scale is graduated for a current upto 100 amps.

After an additional shunt has been connected to this ammeter it becomes possible to measure currents upto 750 amperes by this meter. The value of shunt –resistance is

[New NCERT /XII/131]

- 1) 2Ω 2) 0.2Ω 3) $2k\Omega$ 4) 20Ω

38) In an a.c. circuit V and I are given by $V=100 \sin (100 t)$ volts , $I=100 \sin (100 t+ \pi / 3)$ mA the power dissipated in the circuit is

[New NCERT /XII/191]

- 1) 10^4 watt 2) 10 watt 3) 2.5 watt 4) 5.0 watt

39) Choose the incorrect statement related to an isobaric process.

[New NCERT /XI/235]

- 1) $\frac{V}{T}$ constant
 2) $W= P\Delta V$
 3) Heat given to a system is used up in raising the temperature only
 4) $\Delta Q > W$

40) A body executes simple harmonic motion .The potential energy (P.E) ,the kinetic energy(KE) and total energy (T.E) are measured as function of displacement x. Which of the following statement is true?

[New NCERT /XI/268]

- 1) P.E is maximum when $x = 0$
 2) K.E. is maximum when $x = 0$
 3) T.E. is zero when $x = 0$
 4) K.E is maximum when x is maximum

41) The graph between angle of deviation (δ) and angle of incidence (i) for a triangular prism represented by

[New NCERT /XII/240]

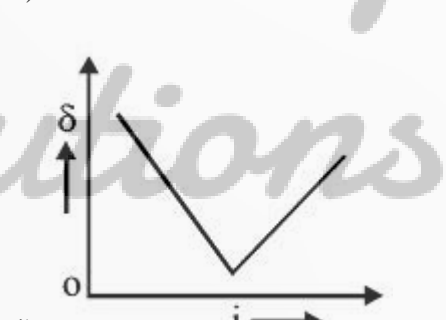
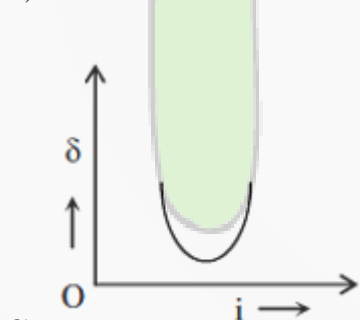
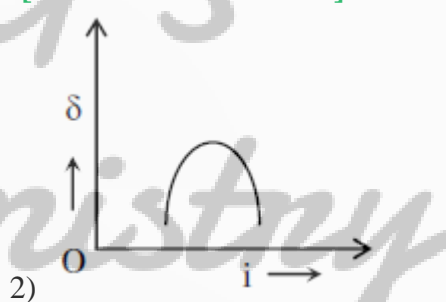
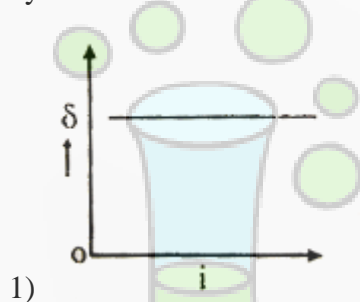

42) If we observe the single slit Fraunhofer diffraction with wavelength λ and slit width b, the width of the central maxima is 2θ .On decreasing the slit width for the same λ

[New NCERT /XII/267]

- 1) θ increase
 2) θ remains unchanged
 3) θ decreases
 4) θ increases or decreases depending on the intensity of light

43) Ratio of volume occupied by a gas H_2 of mass 22gm at two different pressure p and 2p if temperature remains constant is

[New NCERT /XI/247]

- 1) 1:2 2) 2:1 3) 1:4 4) 4:1

44) The displacement y of a particle in a medium can be expressed as $y=10^{-6} \sin \left(100t + 2x + \frac{\pi}{4} \right)$ m

where t is in second and x in meter .The speed of the wave is

[New NCERT /XI/283]

- 1) -141.2kJ/mol 2) -1412 kJ/mol 3) +14.2 kJ/mol 4) +1412kJ/mol
- 55) In the preparation of chlorobenzene from aniline, the most suitable reagent is
[New NECRT/XII/166]
- 1) chlorine in the presence of ultraviolet light
2) chlorine in the presence of AlCl_3
3) nitrous acid followed by heating with Cu_2Cl_2
4) HCl and Cu_2Cl_2
- 56) Calcium carbide when treated with water gives
[New NECRT/XI/315]
- 1) ethylene 2) methane 3) acetylene 4) ethane
- 57) Substitution of one alkyl group by replacing hydrogen of primary amines
[New NECRT/XII/266]
- 1) increases the base strength
2) decreases the base strength
3) remains the same 4)
4) None of the above
- 58) An electron, e_1 is moving in the fifth stationary state, and another electron e_2 is moving in the fourth stationary state. The radius of orbit electron, e_1 is five times the radius of orbit of electron, e_2 calculate the ratio of velocity of electron e_1 (v_1) to the velocity of electron e_2 (v_2)
[New NECRT/XI/46]
- 1) 5:1 2) 4:1 3) 1:5 4) 1:4
- 59) Blood cells retain their normal shape in solution which are
[New NECRT/XII/22]
- 1) hypotonic to blood 2) isotonic blood
3) hypertonic to blood 4) equinormal to blood
- 60) Choose the correct stability order of group 13 elements in their +1 oxidation state.
[Old NECRT/XII/318]
- 1) $\text{Al} < \text{Ga} < \text{In} < \text{Tl}$ 2) $\text{Tl} < \text{In} < \text{Ga} < \text{Al}$
3) $\text{Al} < \text{Ga} < \text{Tl} < \text{In}$ 4) $\text{Al} < \text{Tl} < \text{Ga} < \text{In}$
- 61) Match Column I with Column II.
[New NECRT/XII/232,238]
- | Column I
(Reactinos) | Column II
(Reagents) |
|-----------------------------------|---|
| (A) Benzophenone \rightarrow | (p) LiAlH_4 Diphenylmethane |
| (B) Benzaldehyde \rightarrow | (q) DIBAL -H 1-phenylethanol |
| (C) Cyclohexanone \rightarrow | (r) $\text{Zn}(\text{Hg})/\text{conc.HCl}$ Cyclohexanol |
| (D) Phenyl benzoate \rightarrow | (s) CH_3MgBr Benzaldehyde |
- 1) A-(p), B-(s), C-(r), D-(q) 2) A-(q), B-(s), C-(p), D-(r)
3) A-(s), B-(r), C-(q), D-(p) 4) A-(r), B-(s), C-(p), D-(q)
- 62) PCl_5 is dissociating 50% at 250°C at a total pressure of P atm. If equilibrium constant is K_p , then which of the following relation is numerically correct?
[New NECRT/XI/78]
- 1) $K_p = 3P$ 2) $P = 3K_p$ 3) $P = \frac{2K_p}{3}$ 4) $K_p = \frac{2P}{3}$
- 63) Which one of the following cells can convert chemical energy of H_2 and O_2 directly into electrical energy?
[New NECRT/XII/56]
- 1) Mercury cell 2) Daniell cell
3) Fuel cell 4) Lead storage cell
- 64) Assertion: Smaller the size of an atom greater is the electron gravity
Reason: Electronegativity refers to the tendency of atom to share electrons with other atom.
[New NECRT/XI/90-91]
- 1) If both Assertion and Reason are correct and the Reason is a correct explanation of the Assertion

- 2) If both Assertion and Reason are correct but Reason is not a correct explanation of the Assertion
 3) If the Assertion is correct but Reason is not correct
 4) If the Assertion is incorrect and Reason is correct
- 65) In anti-bonding molecular orbital, electron density is minimum [New NECRT/XI/127]
 1) around one atom of the molecule
 2) between the two nuclei of the molecule
 3) at the region away from the nuclei of the molecule
 4) at no place
- 66) Which of the following reacts with NaOH to give an alcohol? [New NECRT/XII/242]
 1) Propene 2) Butene 3) Ethanal 4) Methanal
- 67) During isothermal expansion of an ideal gas, its [New NECRT/XI/142]
 1) internal energy increases 2) enthalpy decreases
 3) enthalpy remains unaffected 4) enthalpy reduces to zero.
- 68) The salt used for performing 'bead' test in qualitative inorganic analysis is [Practical Chemistry]
 1) $K_2SO_4 \cdot Al_2(SO_4)_3 \cdot 24H_2O$ 2) $FeSO_4 \cdot (NH_4)_2SO_4 \cdot 4H_2O$
 3) $Na(NH_4)HPO_4 \cdot 4H_2O$ 4) $CaSO_4 \cdot 2H_2O$
- 69) A weak acid, HA, has a K_a of 1.00×10^{-5} . If 0.100 mole of this acid dissolved in one litre of water, the percentage of acid dissociated at equilibrium is closed to [New NECRT/XI/195]
 1) 1.00% 2) 99.9%
 3) 0.100% 4) 99.0%
- 70) Gabriel's phthalimide synthesis is used for the preparation of [New NECRT/XII/264]
 1) Primary aromatic amines 2) Secondary amines
 3) Primary aliphatic amine 4) Tertiary amines
- 71) Which of the following statements is not correct for nitrogen? [Old NCERT /XII/72]
 1) Its electronegativity is very high
 2) d-orbitals are available for bonding
 3) It is a typical non-metal
 4) Its molecular size is small
- 72) The correct IUPAC name of the following compound is [New NECRT/XI/266]
-
- 1) 4-methyl-2-nitro-5-oxohept-3-enal
 2) 4-methyl-5-oxo-2-nitrohept-3-enal
 3) 4-methyl-6-nitro-3-oxohept-4-enal
 4) 6-formyl-4-methyl-2-nitrohex-3-enal
- 73) Which of the following statements (s) is /are correct? [New NECRT/XII/287]
 i) Glucose I reduce sugar
 ii) Sucrose is reducing sugar
 iii) Maltose is non-reducing sugar
 iv) Fructose is a reducing sugar
 v) Fructose is a reducing sugar
 1) (i) and (ii) only 2) (i) and (v) only
 3) (i), (iv) and (v) only 4) All of these
- 74) IUPAC name of $[Pt(NH_3)_2Cl(NO_2)]$ is [New NECRT/XII/123]
 1) Platinum diamminnechloronitrite

- 2) Chloronitrito-N-ammineplatinum (II)
 3) Diamminechloridonitrito –N-platinum (II)
 4) Diamminechloridonitrito –N-platinate (II)
- 75) Which of the following does not represent the correct order of the properties indicated? [New NECRT/XII/93,102]
- 1) $\text{Ni}^{2+} > \text{Cr}^{2+} > \text{Fe}^{2+} > \text{Mn}^{2+}$ (size)
 - 2) $\text{Sc} > \text{Ti} > \text{Cr} > \text{Mn}$ (size)
 - 3) $\text{Mn}^{2+} > \text{Ni}^{2+} > \text{Co}^{2+} > \text{Fe}^{2+}$ (unpaired electron)
 - 4) $\text{Fe}^{2+} > \text{Co}^{2+} > \text{Ni}^{2+} > \text{Cu}^{2+}$ (unpaired electron)
- 76) Statement I: Magnetic quantum number determines the size of the orbital
 Statement II: Spin quantum number of an electron relative to the chosen axis [New NECRT/XI/55-56]
- 1) Both statement I and II are correct
 - 2) Both statement I and II are incorrect
 - 3) Statement I is correct but statement II is incorrect
 - 4) Statement II is correct but statement I is incorrect
- 77) The plot that represents the zero order relation is : [New NECRT/XII/106]



- 78) Match Column I with Column II [New NECRT/XI/18]

Column I	Column II
(A) 28 g of He	(p) 2 moles
(B) 46 g of Na	(q) 7 moles
(C) 60 g of Ca	(r) 1 mole
(D) 27 g of Al	(s) 1.5 mole

- 1) A-(s), B(r), C-(q), D-(p)
- 2) A-(p), B(r), C-(q), D-(s)
- 3) A-(r), B (q), C-(p), D-(s)
- 4) A-(q), B (p), C-(s), D-(r)

- 79) Phenol does not undergo nucleophilic substitution reaction easily to: [New NECRT/XII/206-207]
- 1) acidic nature of phenol
 - 2) partial double bond character of C-OH bond
 - 3) partial double bond character of C-C bond
 - 4) instability of phenoxide ion

- 80) Assertion: CH_2Cl_2 is non-polar and CCl_4 is polar molecule.
 Reason: Molecule with zero dipole moment is non-polar in nature [New NECRT/XI/110-112]
- 1) If both Assertion and Reason are correct and the Reason is a correct explanation of the Assertion
 - 2) If both Assertion and Reason are correct but the Reason is not correct explanation of the Assertion
 - 3) If the Assertion is correct but Reason is incorrect
 - 4) If the Assertion is incorrect but Reason is correct

81) Increasing order of reactivity of the following compounds for S_N^1 substitution is:

[New NECRT/XII/174]

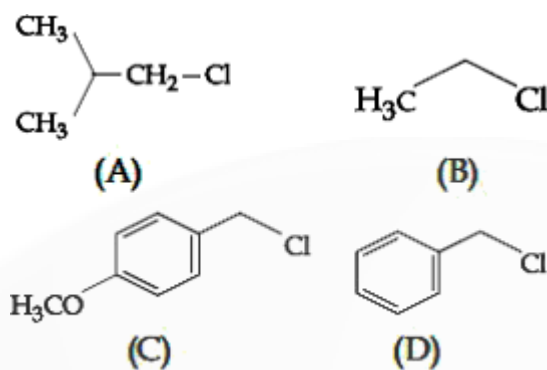

- 1) (B)<(C)<(D)<(A) 2) (B)<(C)<(A)<(D)
 3) (B)<(A)<(D)<(C) 4) (A)<(B)<(D)<(C)

82) If a system is at equilibrium the rate of forward to the reverse reaction is:

[New NECRT/XI/172]

- 1) less 2) equal 3) high 4) at equilibrium

83) Which of the following reagents will convert p-methylbenzenediazonium chloride into p-cresol?

[New NECRT/XII/276]

- 1) Cu powder 2) H₂O
 3) H₃PO₂ 4) C₆H₅OH

84) Lanthanoid which has the smallest size in +3 state is

[New NECRT/XII/109]

- 1) Tb 2) Er 3) Ce 4) Lu

85) Oxidation number of cobalt in K[Co(CO)₄] is

[New NECRT/XII/240]

- 1) +1 2) +3 3) -1 4) -3

86) Which of the following statements (s) is/are correct?

[Practical Chemistry]

- (i) Ferric chloride test is given by -OH group
 (ii) A ketonic group gives both, 2,4-DNP test and Fehling 's test
 (iii) A 10 and 20 amine can be distinguished by Hinsberg's test
 (iv) Sodium metal dissolves in a solution of phenol
 (v) Phthalein test is given by -OH group

- 1) (i), (iii), (iv) and (v) 2) (ii), (iii) and (iv)
 3) (i), (ii) and (iii) 4) (ii) and (v)

87) Assertion: Aliphatic carboxylic acids having upto four carbon atoms are miscible in water

Reason: Simple aliphatic carboxylic shows formation of hydrogen bond with water

[New NECRT/XII/249]

- 1) If both Assertion and Reason are correct and the Reason is a correct explanation of the Assertion
 2) If both Assertion and Reason are correct but Reason is not a correct explanation of the Assertion
 3) If the Assertion is correct but Reason is incorrect
 4) If the Assertion is incorrect and Reason is incorrect

88) The vapour pressure of two volatile liquids A and B at 25^o C are 50 Torr and 100 Torr, respectively. If the liquid mixture contains 0.3 mole fraction of A, then the mole fraction of liquid B in the vapour

phase is $\frac{x}{17}$. The value of x is -----

[New NECRT/XII/10-11]

- 1) 1 2) 15 3) 14 4) 6

89) Denaturation of proteins leads to loss of its biological activity by

[New NECRT/XII/294]

- 1) Formation of amino acids
 2) Loss of primary structure
 3) Loss of both primary and secondary structures
 4) Loss of both primary and tertiary structures

- 90) $2C_6H_5CHO \xrightarrow[H_2O]{OH^-} C_6H_5CH_2OH + C_6H_5COO^-$. Which of the following statements are correct regarding the above reduction of benzaldehyde to benzyl alcohol? [New NECRT/XII/242]
- One hydrogen is coming from H_2O as H^+ and another from C_6H_5CHO as H^-
 - One hydrogen is coming from H_2O as H^- and another from C_6H_5CHO as H^+
 - One hydrogen from H_2O and another from C_6H_5CHO , both in the form H^-
 - The reduction is an example of disproportionation reaction
 - One hydrogen from H_2O and another from C_6H_5CHO , both in the form H^+
- (i), (ii) and (v)
 - (i) and (iv)
 - (ii),(iii) and (v)
 - (iii) and (iv)

PART-III BOTANY

- 91) Connell's elegant field experiments are related to barnacle, in which superior barnacle *Balanus* dominates the inter tidal area, and excludes the smaller barnacle *Chthamalus* from that zone. This phenomenon is called [New NECRT/XII/199]
- competitive exclusion principle
 - competitive release
 - interspecific competition
 - none of the above
- 92) Statement I: A mature sieve element does not have cytoplasm
Statement II: The nucleus and vacuole are absent in mature sieve element [Old NECRT/XI/88]
- Both Statement I and Statement II are incorrect
 - Statement I is correct but Statement II is incorrect
 - Statement I is incorrect but Statement II is correct
 - Both Statement I and Statement II are correct
- 93) Match the terms in Column-I with their description in Column-II and choose the correct option [New NECRT/XII/56-57,69]
- | Column-I | | | | Column-II |
|-------------------------------------|--|--|--|---|
| A. Dominance | | | | (I) Many genes govern a single character |
| B. Codominance | | | | (II) In a heterozygous organism, only one allele expresses itself |
| C. Multiple allele themselves fully | | | | (III) In a heterozygous organism, both alleles express |
| D. Polygenic inheritance | | | | (IV) Alternative forms of same gene |
- | A | B | C | D |
|-------|-----|----|-----|
| 1) II | I | IV | III |
| 2) II | III | IV | I |
| 3) IV | I | II | III |
| 4) IV | III | I | II |
- 94) Assertion (A): Mitosis division results in the production of dipole cells.
Reason (R): Synapsis occurs during zygotene of meiosis. [New NECRT/XI/126]
- Both (A) and (R) are correct but (R) is not the correct explanation of (A)
 - (A) is correct but (R) is not correct
 - (A) is not correct but (R) is correct
 - Both (A) and (R) are correct but (R) is the correct explanation of (A)
- 95) Which one of the following pairs of geographical areas show maximum biodiversity in our country? [New NECRT/XII/225]
- Sunderbans and Rann of Kutch
 - Eastern Ghats and West Bengal
 - Eastern Himalaya and Western Ghats
 - Kerala and Punjab
- 96) A bryophyte differs from pteridophytes in having [New NECRT/XI/29]
- archegonia
 - lack of vascular tissue
 - swimming antherozoids
 - independent gametophytes

- 97) From the statements given below choose the correct option that are true for a typical female gametophyte of a flowering plant [New NECRT/XII/9,11]
- 1) It is eight –nucleate and seven-celled at maturity
 - 2) It is free-nuclear during the development
 - 3) It is situated inside the integument, but outside the nucellus.
 - 4) It has an egg apparatus situated at the chalazal end.
- 1) (i) and (iv) 2) (ii) and (iii)
 3) (i) and (ii) 4) (ii) and (iv)

- 98) Which of the following pair is not correctly matched? [New NECRT/XI/145]
- 1) C₃ plant –Maize
 - 2) C₄ plant –Kranz anatomy
 - 3) Calvin cycle –PGA
 - 4) Hatch and Slack pathway –Oxaloacetic acid

- 99) Who proved that DNA is basic genetic material? [New NCERT /XII/85]
- 1) Griffith 2) Watson
 - 3) Boveri and Sutton 4) Hershey and Chase

- 100) Match column –I with column-II and choose the correct option.

[In Syllabus, Not in NCERT /XI]

Column-I

(Members of Leguminosae)

- A. Gram, sem, moong, soyaben
- B. Soyabean, groundnut
- C. Indigofera
- D. Sunhemp

1) A-I; B-II; C-III; D-IV

3) A-II; B-IV; C-III; D-I

Column-II

(Economic importance).

- I. Fibres
- II. Dye
- III. Edible oil
- IV. Pulses

2) A-IV; B-III; C-II; D-I

4) A-I; B-III; C-IV; D-II

- 101) Gene with multiple phenotypic effect known as [New NECRT/XII/69]
- 1) hypostatic gene
 - 2) duplicate genes
 - 3) pleiotropic genes
 - 4) complementary gene

- 102) Match the scientist given column-I with their work, given column-II & select the correct answer using the codes given below. [New NECRT/XI/134-135]

Column -I

- A. Priestly
- B. Jan Ingenhousz

C. Sachs

D. Engelmann

1) A-IV; B-III; C-II; D-I

3) A-II; B-I; C-IV; D-III

Column II

I. Determined the action spectrum of chlorophyll

II. Provided evidence that in green parts of plant glucose is made & stored as starch

III. Plants purify air only in the presence of light

IV. Revealed the essential role of air in the grown plants

2) A-IV; B-I; C-II; D-III

4) A-II; B-I, C-III; D-IV

- 103) Statement I: Pneumatophores shows growth vertically downward.

Statement II: Stem tendrils develop from axillary bud.

[Old NECRT/XI/67]

- 1) Both Statement I and Statement II are incorrect
- 2) Statement I is correct but Statement II is incorrect
- 3) Statement I is incorrect but Statement II is correct
- 4) Both Statement I and Statement II are correct

- 104) Intine of pollen grain is made of [New NECRT/XII/7]
- 1) callose 2) pecto-cellulose
 - 3) cellulose 4) sporopollenin

- 105) During Anaphase-I of meiosis [New NECRT/XI/127]
- 1) homologous chromosome separate
 - 2) non-homologous autosomes separate
 - 3) sister chromatids separate
 - 4) non- sister chromatids separate

- 106) Assertion (A): Adenine cannot pair with cytosine
Reason (R) : Adenine and cytosine do not have a perfect match between hydrogen donor and hydrogen acceptor sites. Hence , they cannot pair.

[New NECRT/XII/81]

- 1) Both (A) And (R) are correct but (R) is not the correct explanation of (A)
- 2) (A) is correct (R) is not correct
- 3) (A) is not correct but (R) is correct
- 4) Both (A) And (R) are correct but (R) is the correct explanation of (A)

- 107) A peacock eats snakes which eat frogs. Frogs which in turn thrive on leaves plants. The peacock is
[New NECRT/XII/212]

- 1) Primary consumer
- 2) Secondary consumer
- 3) decomposer
- 4) apex of the food pyramid

- 108) Read the following statements and choose the set of correct statement:

[New NECRT/XII/83-84]

- i) Euchromatin is loosely packed chromatin
- ii) Heretrochromatin is transcriptionally active
- iii) Histone octomer is wrapped by negatively charged DNA is nucleosome
- iv) Hisstone are rich in lysine and arginine
- v) A typical nucleosome contains 400 bp of DNA helix

- 1) (i), (iii), (iv) only
- 2) (ii), (iv) only
- 3) (i), (iii), (v) only
- 4) (ii), (iv), (v) only

- 109) Cork cambium and vascular cambium are

[Old NECRT/XI/85]

- 1) parts of secondary xylem and phloem
- 2) parts of pericycle
- 3) lateral meristems
- 4) apical meristems

- 110) Match the growth regulators in column-I with the process in column-II and choose the correct combination
[New NECRT/XI/175-177]

Column-I

- A. Auxin
- B. Gibberellin
- C. Cytokinin
- D. Ethylene

Column-II

- I. Ripened organs
- II. Callus
- III. Coleoptile of oat seeding
- IV. Sterile filtrates of fungus

- 1) A-III; B-IV; C-II; D-I
- 3) A-IV; B-III; C-I'd-II

- 2) A-I; B-IV-; C-II; D-III
- 4) A-II; B-I; C-IV; D-III

- 111) Frame shift mutation occurs when

[New NECRT/XII/98]

- 1) base is deleted or added
- 2) base is added
- 3) base is deleted
- 4) anticodons are not present

- 112) Statement I: Sutton and Boveri noted that the behaviour of chromosomes was parallel to the behaviour of genes

Statement II: Sutton gave chromosomal theory of inheritance and he united the knowledge of chromosomal segregation with Mendalian principle of segregation

[New NECRT/XII/65]

- 1) Both Statement I and Statement II are incorrect
- 2) Statement I is correct but Statement II is incorrect
- 3) Statement I is incorrect but Statement II is correct
- 4) Both Statement I and Statement II are correct

- 113) In growth pattern (r) is

[New NECRT/XII/194]

- 1) carrying capacity
- 2) intrinsic rate of natural increase
- 3) environmental resistance
- 4) biotic potential

- 114) Which of the following statements related to G_0 stage of the cell cycle are correct?

[New NECRT/XI/122]

- i) It is quiescent stage.
- ii) In this phase, cell cycle is stopped
- iii) G_0 cells do not grow or proliferate but metabolically active
- iv) G_0 cells can divided in response to some stimulus

- 1) (i), and (ii)
- 2) (i),(ii) and(iii)

- 3) only (i) and (iv) 4) All of these
- 115) Endemic plants and animals are those which are [New NECRT/XII/224]
 1) cosmopolitan in distribution 2) restricted to certain area.
 3) found in arctic region 4) gregarious in habit
- 116) Assertion (A) : Asexual reproduction in liverworts takes place [New NECRT/XI/29]
 Reason (R) : Gemmae are helpful in propagating liverworts different locality
 1) Both (A) and (R) are correct but (R) is not the correct explanation of (A)
 2) (A) is correct but (R) is not correct
 3) (A) is not correct but (R) is correct
 4) Both (A) and (R) are correct but (R) is the correct explanation of (A)
- 117) Match the number of carbon atoms given in column-I with that of the compounds given in column-II and select the correct option. [New NECRT/XI/159]
- | Column-I | Column-II |
|----------------|----------------------------------|
| A. 4C compound | I. Acetyl CoA |
| B. 2C compound | II. Pyruvate |
| C. 5C compound | III. α -ketoglutaric acid |
| D. 3C compound | IV. Malic acid |
- 1) A-II; B-IV; C-III; D-I 2) A-IV; B-I; C-III; D-II
 3) A-III; B-I; C-IV; D-II 4) A-IV; B-III; C-I; D-II
- 118) Which process is used for amplification or multiplication of DNA for finger printing? [New NECRT/XII/106]
 1) polymerase chain reaction (PCR) 2) nesslerisation
 3) southern blotting 4) northern blotting
- 119) Which of the following statement regarding family Brassicaceae is correct? [In syllabus, Not In NCERT/XI]
 1) Flowers bisecual, cruciform corolla
 2) Statements usually 6, tetranamous
 3) Inflorescence typically racemose or corymbose raceme
 4) All of these
- 120) Statement I: The chromosomal material become untangled during the process of chromatin condensation
 Statement II: In the S and G₂ phase, the new DNA molecules formed are not distinct but intertwined. [New NECRT/XI/122]
 1) Both Statement I and Statement II are incorrect
 2) Statement I is correct but Statement II is incorrect
 3) Statement I is incorrect but Statement II is correct
 4) Both Statement I and Statement II are correct
- 121) in a food web, each successive trophic level has [New NECRT/XII/120]
 1) increased total energy content 2) less total energy content
 3) more total energy content 4) non-essential energy content
- 122) The total requirement of ATP & NADPH for each molecule of CO₂ fixed & reduced in photosynthesis in the Calvin cycle is [New NECRT/XI/143]
 1) 2 ATP & 2 NADPH 2) 2 ATP & 3 NADPH
 3) 3 ATP & 2 NADPH 4) 4 ATP & 3 NADPH
- 123) Which of gibberellic acid is used to speed up the malting process in brewing industry? [New NECRT/XI/176]
 1) GA₁ 2) GA₂ 3) GA₃ 4) None of these
- 124) Which of the following statements (s) about algae is/are correct? [New NECRT/XI/24, 26]
 (i) Algae are chlorophyll bearing simple, thalloid, and heterotrophic and aquatic (both fresh water and marine) organisms.
 (ii) Algae reproduce by vegetative means only
 (iii) Fusion of two gametes dissimilar in size is termed as oogamous
 (iv) A few of the massive forms of algae such as kelps, form massive plant bodies. They may reach a height of 100 meters
 (v) Algae are not useful to man

- 2) one daughter cell remains meristematic while the other daughter cell differentiates and matures.
 3) of the effect of environment on mitosis.
 4) None of the above
- 133) Select the correct statements (i-v) regarding taxonomic categories [New NECRT/XI/6]
 (i) Each step or rank in hierarchy is called taxonomic category
 (ii) Species is a group of individual organisms with fundamental similarities capable of breeding among themselves
 (iii) Taxonomic studies of all unknown organisms have led to the development of common categories like kingdom, phylum, or division, class, order, family, level.
 (iv) Lower the category, greater is the difficulty of determining the relationship to other taxa at the same level.
 v) Phylum includes related orders.
 1) (i) and (ii) only
 2) (ii), (v) and (iv) only
 3) (i),(ii) and (iii) only
 4) All of these
134. Lactose operon produces enzymes [New NECRT/XII/100]
 1) β – galactosidase, permease and glycogen synthetase.
 2) β – galactosidase, permease and transacetylase
 3) permease, glycosen , synthetase and transacetylase
 4) β – galactosidase, permease and phosphoglucose isomerase.
- 135) Energy accumulate in ATP in [New NECRT/XI/154]
 1) disulphide bond
 2) hydrogen bonds
 3) high energy phosphate bond
 4) ester bond

PART-IV ZOOLOGY

- 136) Statement I: Disease or infections which are transmitted through sexual intercourse are collectively called sexually transmitted infections.
 Statement II: STD's if not properly treated may lead to pelvic inflammatory diseases ,abortion ,still birth Ectopic pregnancies infertility or even cancer of reproductive tract. [New NCERT/XII/47]
 1) Both Statement I and Statement II are incorrect
 2) Statement I is correct but Statement II is incorrect
 3) Statement I is incorrect but Statement II is correct
 4) Both Statement I and Statement II are correct
- 137) Match List –I with List –II [New NCERT/XII/134-135]
- | List-I | List-II |
|---------------------|-----------------|
| A) Cellular barrier | (i) Interferons |
| B) Cytok barrier | (ii) Mucus |
| C) Physical barrier | (iii) Monocyte |
| D) Physiological | (iv) Salvia |
- 1) (A)-(iii) (B)-(i) (C)-(ii) (D)-(iv)
 2) (A)-(ii) (B)-(iii) (C)-(iv) (D)-(i)
 3) (A)-(ii) (B)-(iii) (C)-(i) (D)-(iv)
 4) (A)-(iii) (B)-(iv) (C)-(ii) (D)-(i)
- 138) Which of the following hormone/enzyme is/are correctly paired with its function? [New NCERT/XI/212]
- 1) Renin : Enzyme that catalyse the formation of angiotensin I
 2) Aldosterone : Regulates water reabsorption at the distal convoluted tubule
 3) Anti-diuretic hormone (ADh) –it is a powerful vasoconstrictor that simulates the secretion of aldosterone
 4) Angiotensin sin –II –Promotes reabsorption of sodium at distal convoluted tubule
 1) Only (i)
 2) Only (ii)
 3) (i), (ii) and (iii)
 4) (ii), (iii) and (iv)
- 139) The bone cells present in the space called [Old NCERT/XI/104]
 1) Osteoclast
 2) Lacunae
 3) Caveolae
 4) Osteoblast
- 140) Corpus callosum is responsible for the connectional [New NCERT/XI/236]

- 1) two optic thalamus
3) two cerebellar hemispheres
- 2) two ventricles of brain
4) two cerebral hemispheres
- 141) Assertion (A): In females, parturition occurs after the pregnancy
Reason(R): Signal for parturition originates from fully developed embryo.
[New NCERT/XII/38]
1) Both (A) and (R) are correct but (R) is not the correct explanation of (A)
2) (A) is correct but (R) is not correct
3) (A) is not correct but (R) is correct
4) Both (A) and (R) are correct but (R) is the correct explanation of (A)
- 142) During heat shock to the bacterium, the temperature used for giving thermal shock is
[New NCERT/XII/171]
1) 82°C 2) 100°C 3) -196°C 4) 42°C
- 143) Aquatic annelids (like Nereis) possess lateral appendages called -----, which help in swimming
[New NCERT/XI/43]
1) visceral hump 2) parapodia
3) radula 4) spicules
- 144) Listed below are four respiratory capacities (A-D) in column I and four Jumbled respiratory volume of a normal human adult in column II
Column I Column II [New NCERT/XI/186-187]
A. Residual volume I. Additional volume of air, a person can inspire by a forcible inspiration
B. Vital capacity II. Total volume of air a person can inspire after a normal expiration
C. Inspiratory reserve volume III. Volume for air remaining in the lungs even after a forcible expiration
D. Inspiratory capacity IV. The maximum volume of air a person can breath in after a forced expiration
- Which one of the following is the correct matching of two capacities and volume?
1) A-I; B-II; C-III; D-IV 2) A-IV; B-III; C-I; D-II
3) A-II; B-III; C-IV; D-I 4) A-III; B-IV; C-I; D-II
- 145) In a agarose gel electrophoresis, DNA molecules are separated on the basis of their
[New NCERT/XII/168]
1) charge only 2) size only
3) charge to size ratio 4) All of these
- 146) GEAC stands for [New NCERT/XII/184]
1) Genome Engineering Action Committee
2) Ground Environmental Action Committee
3) Genetic Engineering Approval Committee
4) Genetic and Environmental Approval Committee
- 147) Statement I: Rh grouping in human is based on the presence or absence of rhesus antigen on RBCs surface
Statement II: Nearly 80% of humans possess Rh antigen and this called Rh positive
[New NCERT/XI/196]
1) Both Statement I and Statement II are incorrect
2) Statement I is correct but Statement II is incorrect
3) Statement I is incorrect but Statement II is correct
4) Both Statement I and Statement II are correct
- 148) Consumption of tobacco leads to [In Syllabus, Not in NERT/XII]
1) Damage of liver 2) cough and irritation
3) Loss of vision 4) Changing mood and temper

149) Match the following columns.

[New NCERT/XI/244-247]

Column I

- A. Epinephrine
B. Testosterone
C. Glucagon
D. Atrial natriuretic factor

Column II

- I. Stimulates in muscle growth
II. Decreases in blood pressure
III. Breakdown of glycogen in liver
IV. Increase heart beat

1) A-II; B-I; C-III; D-IV

2) A-IV; B-I; C-III-D-II

3) A-I; B-II; C-III-D-IV

4) A-I; B-IV; C-II-D-III

150) Read the following (i to v) statements and select the one option that contains both correct statements

[New NCERT/XI/219-220]

i) Z-line present in the centre of the I band.

ii) Thin filaments are firmly attached to the M-line

iii) The central part of thick filaments, not overlapped by thin filaments is called Z-band

iv) The thin filaments are firmly attached to the 'Z' line

v) Actin filaments are thicker as compared to the myosin filaments

1) (i) and (iv)

2) (ii),(v) and (iii)

3) (i) and (iii)

4) (ii) and (iv)

151) Statement I: Filtration slits are minutes spaces between the podocytes of Bowman's capsule
Statement II: All the constituents of plasma except proteins can pass through filtration slits into the lumen of Bowman's capsule

[New NCERT/XI/208]

1) Both Statement I and Statement II are incorrect

2) Statement I is correct but Statement II is incorrect

3) Statement I is incorrect but Statement II is correct

4) Both Statement I and Statement II are correct

152) When semen is released by the penis into the vagina during copulation, then it is called-----

[New NCERT/XII/28]

1) ovulation

2) insemination

3) menstruation

4) gametogenesis

153) Assertion (A): Enzyme have active sites and substrates have reactive sites on their surface respectively

Reason (R) : Active and reactive sites push the enzyme and substrate molecules away from each other

[New NCERT/XI/112-113]

1) Both (A) and (R) are correct but (R) is not the correct explanation of (A)

2) (A) is correct but (R) is not correct

3) (A) is not correct but (R) is correct

4) Both (A) and (R) are correct but (R) is the correct explanation of (A)

154) Progestasert and LNG -20 are

[New NCERT/XII/44]

1) implants

2) copper releasing IUDs

3) non-medicated IUDs

4) hormone releasing IUDs

155) Match the hominids with their correct brain size

[New NCERT/XII/124]

(A) Homo habilis (I) 900 cc

(B) Neanderthal man (II) 1350 cc

(C) Homo erectus (III) 650-800 cc

(D) Homo sapiens (IV) 1400 cc

(A) (B) (C) (D)

1) (III) (I) (IV) (II)

2) (III) (II) (I) (IV)

3) (III) (IV) (I) (II)

4) (IV) (III) (I) (II)

156) The ciliated columnar epithelial cells in humans occur in

[Old NCERT/XI/208]

1) Eustachian tube and stomach lining

2) bronchioles and fallopian tubes

3) bile duct and oesophagus

4) fallopian tubes and urethra

157) Match the Column-I with Column-II and select the correct options using the code's given below:

[New NCERT/XII/30,32-33]

Column-I	Column II
(A) Mons pubis	(I) Membrane on ovum
(B) Corpus luteum	(II) Finger –like structure
(C) Zonz pellucida	(III) Female external genitalia
(D) Clitoris	(IV) Graafian follicle

- | | | | |
|----------|------|-------|------|
| (A) | (B) | (C) | (D) |
| 1) (III) | (I) | (IV) | (II) |
| 2) (I) | (IV) | (III) | (II) |
| 3) (III) | (IV) | (II) | (I) |
| 4) (III) | (IV) | (I) | (II) |

158) Statement I: Male frogs can croak louder than females because of vocal sacs

Statement II: Frogs exhibit dimorphism.

[New NCERT/XI/81]

- 1) Both Statement I and Statement II are incorrect
- 2) Statement I is correct but Statement II is incorrect
- 3) Statement I is incorrect but Statement II is correct
- 4) Both Statement I and Statement II are correct

159) What is common between typhoid and pneumonia?

[New NCERT/XII/146]

- 1) They are all bacterial diseases
- 2) They are all endemic diseases
- 3) They are all viral diseases
- 4) They are all communicable diseases

160) Thrombocytes are also called

[New NCERT/XI/194]

- | | |
|-------------------|----------------|
| 1) platelets | 2) lymphocytes |
| 3) helper T cells | 4) mast cells |

161) IUDs are small objects made up of plastic or copper that are inserted in the uterine cavity.

Which of the following statements are correct about IUDs?

[New NCERT/XII/44-45]

- i) IUDs decrease phagocytosis of sperm within the uterus.
- ii) The released copper ions suppress the sperm motility
- iii) IUDs make the cervix hostile to the sperm
- iv) IUDs suppress the fertilization capacity of sperm
- v) The IUDs require surgical intervention for their insertion in the uterine activity.

Choose the most appropriate answer from the options given below.

- | | |
|-------------------------|-----------------------|
| 1) (ii), (iii) and (iv) | 2) (iv) and (v) only |
| 3) (ii) and (iii) only | 4) (ii) and (iv) only |

162) Transgenic plants are the ones

[New NCERT/XII/181]

- 1) generated by introducing foreign DNA into a cell and regenerating a plant from that cell
- 2) produced after protoplast fusion in artificial medium.
- 3) grown in artificial medium after hybridization in the field
- 4) produced by a somatic embryo in artificial medium

163) Assertion (A) : Sponges have a body organisation of “cellular level”

Reason(R) : There is some physiological division of labour.

[New NCERT/XI/40]

- 1) Both (A) and (R) are correct but (R) is not the correct explanation of (A)
- 2) (A) is correct but (R) is not correct
- 3) (A) is not correct but (R) is correct
- 4) Both (A) and (R) are correct but (R) is the correct explanation of (A)

164) Adenosine deminase deficiency can be permanently cured by which of the following methods?

[New NCERT/XII/183]

- | | |
|---|--------------------------------|
| 1) Bone marrow transplantation | 2) Enzymes replacement therapy |
| 3) Gene therapy at early embryonic stages | 4) All of these |

165) Match List-I with List -II

[New NCERT/XI/108]

List-I	List-II
--------	---------

- (A) Guanine (I) Pigment
 (B) Anthocyanin (II) Polysaccharide
 (C) Cellulose (III) Alkaloid
 (D) Codeine (IV) Purine
- 1) (A)-(I) (B) -IV (C) -(III) (D)-(II)
 2) (A)-(IV) (B) -(I) (C)-(II) (D)-(III)
 3) (A)-(IV) (B) -III (C)-(II) (D)-(I)
 4) (A)-(III) (B) -(I) (C)-(IV) (D)-(II)
166. Which of the following statements are correct for innate immunity? [New NCERT/XII/134]
 i) Bacteria entry through a break in the skin
 ii) Resident phagocytic cells engulf the bacteria
 iii) B-cells are stimulated to produce specific antibodies
 iv) Diapedesis allows new phagocytic leukocytes to invade the infected areas
 1) (iii) and (iv) 2) (i) and (ii)
 3) (i) and (iii) 4) (ii) and (iv)
- 167) The part of the nephron impermeable to water is [New NCERT/XI/209]
 1) proximal tubule 2) distal tubule
 3) ascending limb of Henle's loop 4) collecting duct
- 168) Statement I: When a particular restriction enzyme cuts strand of DNA, Over hanging stretches or sticky ends are formed.
 Statement II: Some restriction enzyme cut the strand of DNA from the centre of palindromic sites [New NCERT/XII/167]
 1) Both Statement I and Statement II are incorrect
 2) Statement I is correct but Statement II is incorrect
 3) Statement I is incorrect but Statement II is correct
 4) Both Statement I and Statement II are correct
- 169) Thymus in mammals is mainly concerned with [New NCERT/XI/243]
 1) regulation of body growth 2) secretion of thyrotropin
 3) regulation of body temperature 4) immunological functions
- 170) Assertion (A) : Fossils are remains of hard part of life forms found in rocks
 Reason(R): None of them appear similar to modern organism. [New NCERT/XI/113]
 1) Both (A) and (R) are correct but (R) is not the correct explanation of (A)
 2) (A) is correct but (R) is not correct
 3) (A) is not correct but (R) is correct
 4) Both (A) and (R) are correct but (R) is the correct explanation of (A)
- 171) Number of floating ribs in human body is [New NCERT/XI/225][Practical skills]
 1) two pairs 2) three pairs
 3) five pairs 4) six pairs
- 172) One of the following is a very unique feature of the mammalian body [New NCERT/XI/50-51]
 1) Homeothermy
 2) Presence of milk producing glands
 3) Four chambered heart
 4) Rib cage
- 173) Match List-I with List-II [New NCERT/XII/164,171]
 List-I List-II
 (A) Gene gun (i) Replacement of a faulty gene by a normal healthy gene
 (B) Gene therapy (ii) Used for transfer of Gene
 (C) Gene cloning (iii) Total DNA in the cells of an organism
 (D) Genome (iv) To obtain identical copies of a particular DNA molecule
- Choose the correct answer from the options given below
 1) A-(ii),(B)-(iii),(C)-(iv),(D)-(i) 2) A-(ii),(B)-(i),(C)-(iv),(D)-(iii)
 3) A-(i),(B)-(iii),(C)-(ii),(D)-(iv) 4) A-(iv),(B)-(i),(C)-(iii),(D)-(ii)
- 174) Level of which hormones are at their highest during the luteal phase (second half the cycle) of the menstrual cycle? [New NCERT/XII/34]

- 1) Estrogen
3) Luteinizing hormone
- 2) Progesterone
4) Follicular stimulating hormone
- 175) Glomerular filtration rate (GFR) in a healthy individual is approximately [New NCERT/XI/209]
1) 100 ml/minute, i.e.180 litres per day
2) 125ml/minute, i.e.180 litres per day
3) 120 ml/minute, i.e.100 litres per day
4) 130 ml/minute, i.e.120 litres per day
- 176) Characteristics of cancer is [New NCERT/XII/141]
1) All tumors are cancers
2) cancers show metastasis
3) cancerous cells show property of contact inhibition
4) All viruses are oncogenic
- 177) Statement I: Neurons are excitable cells. [New NCERT/XI/232]
Statement II: The membrane of neurons in a depolarised state is responsible for excitability
1) Both Statement I and Statement II are incorrect
2) Statement I is correct but Statement II is incorrect
3) Statement I is incorrect but Statement II is correct
4) Both Statement I and Statement II are correct
- 178) Match List-I with List-II regarding the organs of Cockroach [Old NCERT/XI/113]
- | List I | List II |
|-------------------|------------------------------------|
| A) Crop | (i) grinding the food particles |
| B) Proventriculus | (ii) secretion of digestive juice |
| C) Hepatic caecae | (iii) removal of nitrogenous waste |
| D) Malpighian | (iv) storage of food tubules |
- 1) (A)-(i) (B)-(iv) (C)-(iii) (D)-(ii) 2) (A)-(iv) (B)-(i) (C)-(ii) (D)-(iii)
3) (A)-(iii) (B)-(ii) (C)-(i) (D)-(iv) 4) (A)-(ii) (B)-(iv) (C)-(i) (D)-(iii)
- 179) Which of the following steps are catalysed by Taq polymerase in a PCR reaction? [New NCERT/XII/173]
1) Denaturation of template DNA
2) Annealing of primers to template DNA
3) Extension of primer to template DNA
4) All of the above
- 180) The theory of natural selection was given by [New NCERT/XII/113]
1) Lamrack 2) Alfred Wallace
3) Charles Darwin 4) Oparin and Haldane

CG's
Chemistry
Solutions

Feel The Chemistry